

UNITE® 200 PTZ HD Camera



ClearOne® Contacts

Headquarters

5225 Wiley Post Way Suite 500
Salt Lake City, UT 84116

Sales

Tel: +1.801.975.7200
sales@clearone.com

Headquarters

Tel: +1.801.975-7200

Technical Support

Tel: +1.801.974.3760
videotechsupport@clearone.com

Notices

© 2021 ClearOne, Inc. All rights reserved.

Information in this document is subject to change without notice.

Document: DOC-0263-001v1.6, September 2021

Contents

Introduction	1
Remote Control	1
Menu Settings	3
EXPOSURE	3
COLOR	5
NOISE REDUCTION	8
SETUP	8
COMMUNICATION SETUP	9
RESTORE DEFAULT	10
USB 3.0	10
IP Function	11
Access Through a Local Area Network (LAN)	11
Access Through a Wide Area Network (WAN)	12
IP Camera Parameter Setup	12
Control Interface Definition	16
Network Configuration	17
Command List	18
Maintenance and Troubleshooting	24
Camera Maintenance	24
Unqualified Application	24
Troubleshooting	24

Introduction

This user manual provides advanced information regarding control of the ClearOne UNITE 200 PTZ HD Camera. Additional information about the camera is provided in the corresponding Datasheet and Quick-Start Guide, which are available in [ClearOne's Resource Library](#).

Remote Control

1. Standby Button

Press this button to enter standby mode. Press it again to enter normal mode.

Note: Power consumption in standby mode is approximately half of the normal mode

2. Position Buttons

To set preset or call preset

3. * Button

4. Set/Preset Buttons

Set a corresponding numeric key preset position

[PRESET] + Numeric button (0-9)

Note: Preset 0-9 via remote control and the rest from keyboard and the serial port.

5. Pan-Tilt Control Buttons

Press the arrow buttons to perform panning and tilting. Press the [HOME] button to face the camera back to front.

6. Return Button

Press to return to previous menu.

7. Zoom Buttons

Slow Zoom: Zoom In [+] or Zoom Out [-] slowly

Fast Zoom: Zoom In [+] or Zoom Out [-] fast

8. L/R Set Button

Press at the same time as the numeric button 1 [STD] and button 2 [REV] to set the direction of the Pan-Tilt

L/R Set +1[STD]: set the Pan-Tilt turn the same direction as the L/R Set

L/R Set +2[REV]: set the Pan-Tilt turn the opposite direction as the L/R Set

9. Focus Buttons

Press [AUTO] to adjust the focus on the center of the object automatically.

Press [MANUAL] to adjust the focus manually.

Press [FAR] to focus on a far object.

Press [NEAR] to focus on a near object.

10. Camera Select Buttons

Press the button corresponding to the camera you want to control with the remote controller.

11. # Button

Used with other buttons

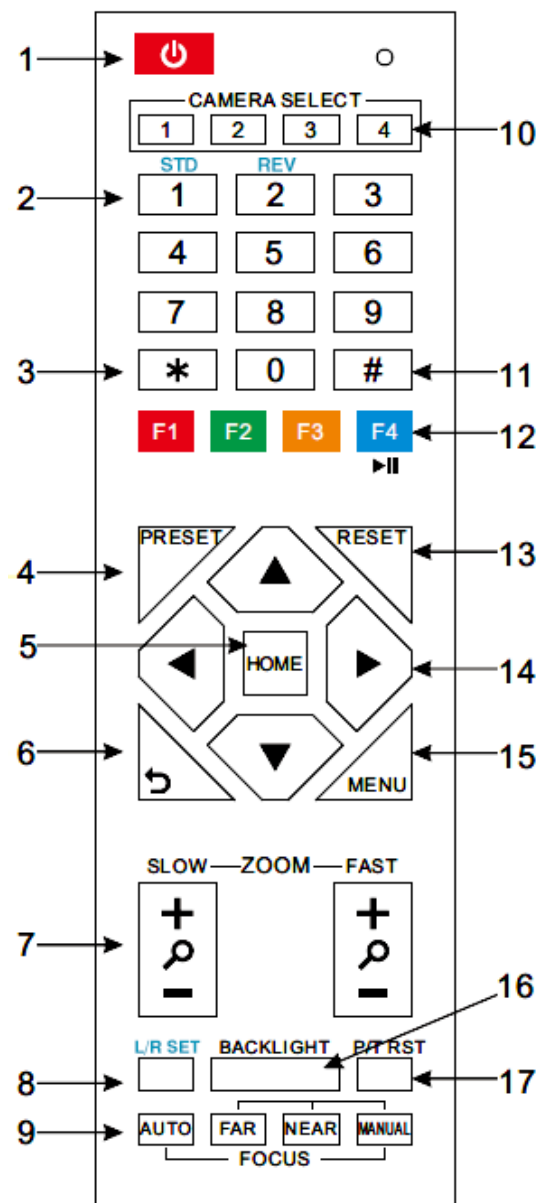

12. Set Camera IR Address Buttons

Function 1. Set camera IR address

[*]+[#]+[F1]: Address 1

[*]+[#]+[F2]: Address 2

[*]+[#]+[F3]: Address 3

[*]+[#]+[F4]: Address 4

Function 2: Image freezing function

Press [F4] to start the freeze function. The word “Freeze” displays in the upper left. After five seconds, the display automatically disappears (though the freeze feature continues). To cancel the freeze, press the [F4] key the word “Unfreeze” displays in the upper left. After five seconds, the display automatically disappears.

13. Reset Buttons

Clear a specific preset: [Reset] + Numeric button (0-9)

Clear all presets: [*]+[#]+[Reset]: Erase all presets

14. Pan/Tilt Control Buttons

Press arrow buttons to perform panning and tilting. Press [HOME] button to face the camera back to front.

15. MENU

Press MENU to enter or exit the OSD menu.

16. BLC (Backlight Compensation) Button

If there is light behind the subject, the subject will appear dark.

Press this button to enable the backlight compensation. Press it again to disable the backlight compensation.

Press the backlight ON / OFF button. To cancel this function, press the backlight ON / OFF button.

Note: The BLC feature is effective only in auto exposure mode.

Note: If light behind the subject exists, the subject appears dark. In this case, press the backlight ON / OFF button. To cancel this function, press the backlight ON / OFF button.

17. Pan/Tilt Reset

Reset Pan/Tilt self-test.

Shortcut Set:

[*]+[#]+[1]: Display OSD menu in English

[*]+[#]+[3]: Display OSD menu in Chinese

[*]+[#]+[5]: Save OSD

[*]+[#]+[6]: Quickly recover the default settings

[*]+[#]+[8]: Show the camera version

[*]+[#]+[9]: Quickly set mount mode (flip/normal)

Menu Settings

Press the [MENU] button to display the main menu. Use the arrow buttons to select the item to be set.

Press the [HOME] button to enter a sub-menu.

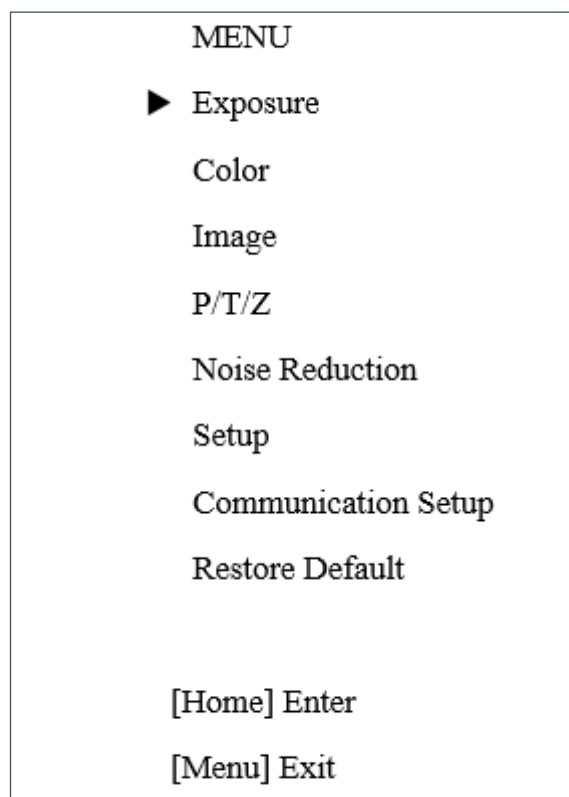

EXPOSURE

Select Exposure from the main menu and press the [HOME] button. The EXPOSURE menu appears.

The table on the following page provides information about Exposure settings.

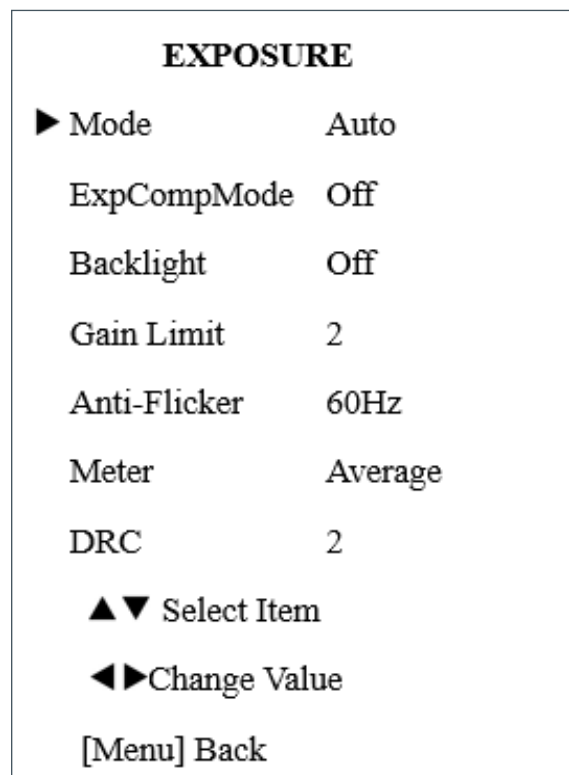

Setting	Description	Options	Effective only when the exposure mode is set to...
Mode		<ul style="list-style-type: none"> • Auto • Manual • SAE • AAE • Bright 	
ExpCompMode	Exposure compensation mode	<ul style="list-style-type: none"> • On • Off 	Auto
ExpComp	Exposure Compensation value	-7 ~ 7	NA Only when ExpCompMode is on.
Gain Limit	Maximum gain limit	0 ~ 15	Auto/AAE/Bright.
Backlight	Set the backlight compensation	<ul style="list-style-type: none"> • On • Off 	Auto.
DRC	DRC strength	0 ~ 8	NA
Bright	Intensity control	00~17	Bright.
Anti-Flicker	Anti-flicker	<ul style="list-style-type: none"> • Off • 50 Hz • 60 Hz 	Auto/Bright.
Meter		<ul style="list-style-type: none"> • Average • Center • Bottom • Top 	NA
Iris	Aperture value	<ul style="list-style-type: none"> • F1.8 • F2.0 • F2.4 • F2.8 • F3.4 • F4.0 • F4.8 • F5.6 • F6.8 • F8.0 • F9.6 • F11.0 • Close 	Manual/AAE
Shutter	Shutter value	<ul style="list-style-type: none"> • 1/30 • 1/60 • 1/90 • 1/100 • 1/125 • 1/180 • 1/250 • 1/350 • 1/500 • 1/725 • 1/1000 • 1/1500 • 1/2000 • 1/3000 • 1/4000 • 1/6000 • 1/10000 	Manual/SAE

COLOR

From the main menu, select Color, then press the [HOME] button.

The system displays the COLOR menu.

COLOR

▶ WB Mode	Auto
RG Tuning	+6
BG Tuning	0
Saturation	100%
Hue	5

▲▼ Select Item

◀▶ Change Value

[Menu] Back

Setting	Description	Options	Effective only when...
WB-Mode	White balance mode	<ul style="list-style-type: none"> <li style="width: 50%;">• Auto <li style="width: 50%;">• OnePush <li style="width: 50%;">• Indoor <li style="width: 50%;">• Manual <li style="width: 50%;">• Outdoor 	NA
RG	Red gain	0 ~ 255	WB-Mode is set to Manual.
BG	Blue gain	0 ~ 255	WB-Mode is set to Manual.
RG Tuning	Red gain fine-tuning	-10 ~ +10	AWB sens is set at Low.
BG Tuning	Blue gain fine-tuning	-10 ~ +10	AWB sens is set at Low.
Saturation	Saturation	60% ~ 200%	NA
Hue	Chroma adjustment	0 ~ 14	NA

IMAGE

From the main menu, select Image, then press the [HOME] button.

The system displays the IMAGE menu.

IMAGE	
▶ Luminance	7
Contrast	9
Sharpness	3
Flip-H	Off
Flip-V	Off
B&W-Mode	Off
Gamma	0.45
Style	<u>CStyle</u>
▲ ▼ Select Item	
◀ ▶ Change Value	
[Menu] Back	

Setting	Description	Options
Luminance	Brightness adjustment	0 ~ 14
Contrast	Contrast adjustment	0 ~ 14
Sharpness	Sharpness adjustment	<ul style="list-style-type: none"> • Auto • 0 ~ 15
Flip-H	Image flipped horizontal	<ul style="list-style-type: none"> • On • Off
Flip-V	Image flipped vertical	<ul style="list-style-type: none"> • On • Off
B&W-Mode:	Image color	<ul style="list-style-type: none"> • On • Off
Gamma		<ul style="list-style-type: none"> • Default • 0.45 • 0.5 • 0.56 • 0.63
Style		<ul style="list-style-type: none"> • Norm • Clarity • Bright • CStyle

P/T/Z

From the main menu, select P/T/Z, then press the [HOME] button.

The system displays the P/T/Z menu.

Setting	Description	Options
SpeedByZoom	The depth of field scale switch	<ul style="list-style-type: none"> • On • Off
AF-Zone	Interested in focusing area	<ul style="list-style-type: none"> • Top • Bottom • Center
AF-Sense	Automatic focusing sensitivity options	<ul style="list-style-type: none"> • Low • High • Normal
L/R Set		<ul style="list-style-type: none"> • STD • REV
Display Info		<ul style="list-style-type: none"> • On • Off
Image Freeze		<ul style="list-style-type: none"> • On • Off
Digital Zoom		<ul style="list-style-type: none"> • 2X • 4x • 8X • 16X • Off
Call Preset Speed		1 - 24

P/T/Z

▶ SpeedByZoom On

AF Zone Center

AF-Sense High

L/R Set STD

Display Info On

Image Freeze Off

Digital Zoom Off

Call Preset Speed 24

▲▼ Select Item

◀▶ Change Value

[Menu] Back

NOISE REDUCTION

From the main menu, select Noise Reduction, then press the [HOME] button.

The system displays the NOISE REDUCTION menu.

Setting	Description	Options
NR2D-Level	2D noise reduction	• Off • 1 - 5 • Auto
NR3D-Level	3D noise reduction	• Off • 1 - 8
D-HotPixel	Dynamic bad points	• Off • 1 - 5 • Auto

NOISE REDUCTION

▶ NR2D-Level off

NR3D-Level 3

D-HotPixel Off

▲▼ Select Item

◀▶ Change Value

[Menu] Back

SETUP

From the main menu, select Setup, then press the [HOME] button.

The system displays the SETUP menu.

Setting	Description	Options
Language	Menu language	• EN • Russian • Chinese
System Frequency		• 50 Hz • 60 Hz

SETUP

▶ Language EN

System Freq 60HZ

▲▼ Select Item

◀▶ Change Value

[Menu] Back

COMMUNICATION SETUP

From the main menu, select Setup, then press the [HOME] button.

The system displays the COMMUNICATION SETUP menu.

Setting	Description	Options
Protocol	Control protocol type	<ul style="list-style-type: none"> • AUTO • VISCA • PELCO-D • PELCO-P
P_D_Address	PELCO-D protocol	0 ~ 254
P_P_Address	PELCO-P protocol	0 ~ 31
V_AddrFix	Set whether users can change VISCA address through serial port or keyboard	<ul style="list-style-type: none"> • On (set to On, useless in 88 30 01 FF Command) • Off
V_Address	Protocol address decided according to agreement (AUTO, VISCA protocol)	1 ~ 7
Net Mode	Set the serial port control networking	<ul style="list-style-type: none"> • Serial • Parallel
Baudrate	Serial port baud rate	<ul style="list-style-type: none"> • 2400 • 4800 • 9600

COMMUNICATION SETUP

▶ Protocol VISCA

V_Address 1

V_AddrFix Off

Net Mode Serial

Baudrate 9600

▲ ▼ Select Item

◀ ▶ Change Value

[Menu] Back

RESTORE DEFAULT

From the main menu, select Restore Default, then press the [HOME] button.

The system displays the RESTORE DEFAULT menu.

Setting	Description	Options
Restore	Confirm restore factory settings	<ul style="list-style-type: none"> • Yes • No



Note: Press [HOME] button to confirm.

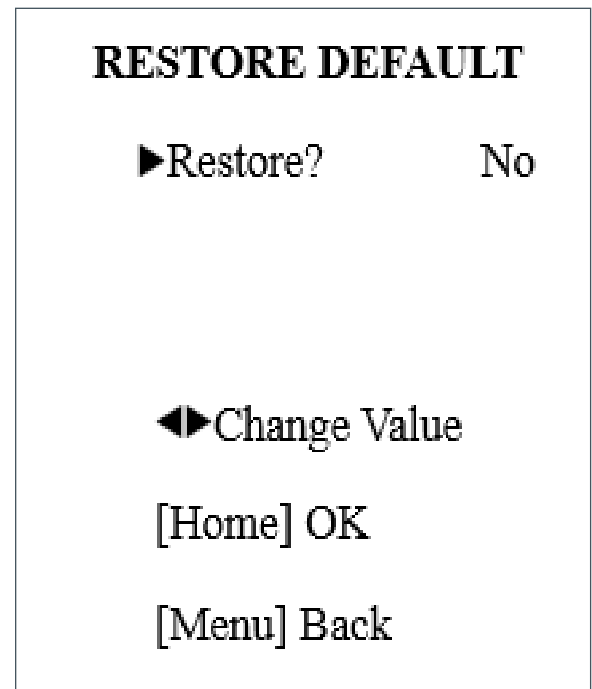

USB 3.0

The camera supports UVC protocol, compatible USB 2.0 & USB 3.0.

USB 3.0 support 1920x1080p/30 max output.

Support OS: Windows 7/8/8.1/10, Linux, Mac OS, etc.

General software are as follows:

- Windows: AMCAP, VLC, Debut Video Capture, etc.
- Linux: V412 software driver and VLC media player, etc.
- Mac OS: FaceTime, iChat, Photo Booth and Debut Video Capture, etc.



Note the following:

- ClearOne recommends the use of AMCAP version 8.0 in Windows, as its software performance is more stable. When you use the high version of AMCAP in a low configuration system, it shows the stream rendering.
- The first time the camera is accessed by USB cable, you must install a plug-in.

IP Function

Access Through a Local Area Network (LAN)

1. Setup IP address

The camera's default IP address is 192.168.100.88.

If you forget the camera's IP address or have changed it, to show the camera IP address on screen, on the remote control, press * and # and 4.

To change the camera's IP address:

- Open the camera's Web interface (see Access Camera's Web Interface later in this Manual for detailed instructions).
- On Web interface page, find "Network"--->Change IP. Enter a new IP address, then Click "Apply".
- Restart camera.

Lan Settings

IP Configuration Type: Fixed IP Address

IP Address: 192.168.100.88

Subnet Mask: 255.255.255.0

Gateway: 192.168.100.1

DNS Address: 192.168.100.1

MAC Address: D4 : E0 : 8E : DB : 18 : 06

Port Settings

HTTP Port number: 80 (80)

RTSP Port: 554 (554)

PTZ Port: 5678 (5678)

Control Protocol Settings

Visca Address: 1 (1~7)

Pelco-D Address: 0 (0~255)

Pelco-P Address: 0 (0~31)

RTMP Settings

First stream: On Off Video Audio

MRL: rtmp://192.168.100.138/live/stream0

Second stream: On Off Video Audio

MRL: rtmp://192.168.100.138/live/stream1

RTSP Settings

RTSP Auth: On Off

ONVIF Setting

ONVIF: On Off

ONVIF Auth: On Off

Multicast Settings

Multicast: On Off

Address: 224.1.2.3

Port: 6688

Apply Cancel

2. Access camera's web

Input http://192.168.100.88 into a browser (Internet Explorer and Firefox work best).



Note the following:

- If you have changed the camera's IP address, enter the new address.
- To access the camera with an IP address, you must be on the same network as the camera.

A login window appears. Input the user name and password. The default for both is "admin".

Your login window may not look exactly like this, depending on your operating system and browser):

Windows Security

The server 192.168.100.88 is asking for your user name and password. The server reports that it is from ..

Warning: Your user name and password will be sent using basic authentication on a connection that isn't secure.

User name

Password

Remember my credentials

OK Cancel

After login, the Web interface appears, as shown below:



Note: If this is the first use of the web interface, you must install the VLC player software.

Access Through a Wide Area Network (WAN)

Dynamic DNS setup for accessing the camera

Once you have set a domain name to the camera, and have forwarded the traffic to the correct address and port number, you can use a domain name to access the camera. The access link is: `http://hostname:port number`.

For example, set up host computer name as: `youdomain.f3322.org`, camera port number: 554. The access link would be: `http://youdomain.f3322.org:554`.

VLC stream media player monitoring

VLC media server procedure

1. Open VLC media player, click "Media"->"Open Network Steam", or type "Ctrl + N".
2. Input stream address: `rtsp://ipaddress:port number/1` (Main stream).
3. Example: `rtsp://192.168.100.88:554/1`
4. `rtsp://ipaddress:port number/2` (Sub stream).
5. Example: `rtsp://192.168.100.88:554/2`



Note: The default RTSP port number is 554.

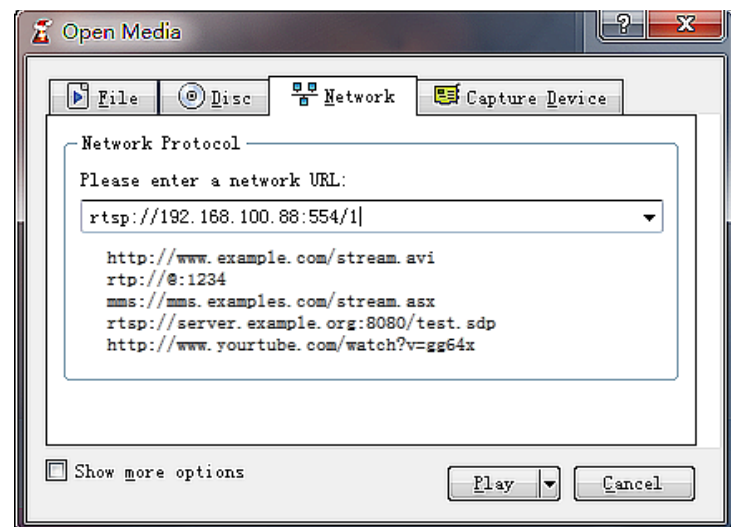

IP Camera Parameter Setup

Homepage

Menu

All pages include two menu bars:

- Real time monitoring: displaying video image
- Parameter setup: with function buttons

Video viewing window

The video viewing window must be the same as video resolution; the bigger the resolution, the bigger the playing area. To show full-screen, double-click the viewing window; to return to initialized size, double-click again.

- Pan-Tilt control: Up, Down, Left, Right, Home button.
- Rate: You can choose vertical speed as 1 - 24, horizontal direction at the rate of 1 - 20. Select corresponding speed and click direction button to realize PTZ speed increase or decrease.
- Zoom In/ Zoom out: for zooming in or zooming out. Focus In/ Focus Out: Focusing on distant objects or Focusing on close objects.
- Set/Call: After you have set PTZ to a desired position, you can save that configuration as a preset for later use. Click the “Set” button to save a preset. At any point later, you can click the “Call” button to call this preset.

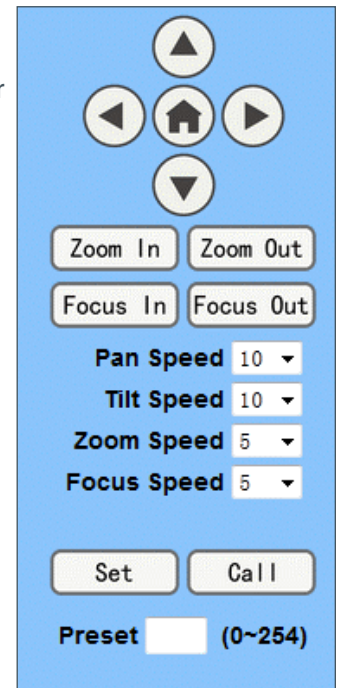

Media

Select “Video”.

- Video format
 - Supports 50 HZ (PAL) and 60 HZ (NTSC), and Dial priority.
- Encode Protocol
 - Supports MJPEG, H.264 and H.265.
- Encode Level
 - Supports baseline, main profile, and high profile.
- Resolution
 - Main bit rate supports 1920x1080, 1280x720 and 1024x576.
 - Minor bit rate supports 720x480, 720x576 and 320x240.
 - The higher the resolution, the clearer the image, but this uses more network bandwidth.
- Bit Rate
 - You can assign bit rate/stream. Generally, the higher the bit rate, the clearer the image. The bit allocation must combine with network bandwidth. If the network bandwidth is too low and the allocated bit rate is too high, the video quality suffers.
- Frame rate
 - You can specify the frame rate. Generally speaking, the higher the frame rate, the smoother the image; the lower the frame rate, the choppy the image.
- I key frame interval
 - Set the interval between 2 and 150. The larger the interval, smaller the response from the viewing window.
- Bit Rate control
 - Options:
 - Constant bit rate: video coder codes per preset speed
 - Variable bit rate: video coder adjusts the speed to gain the best image quality

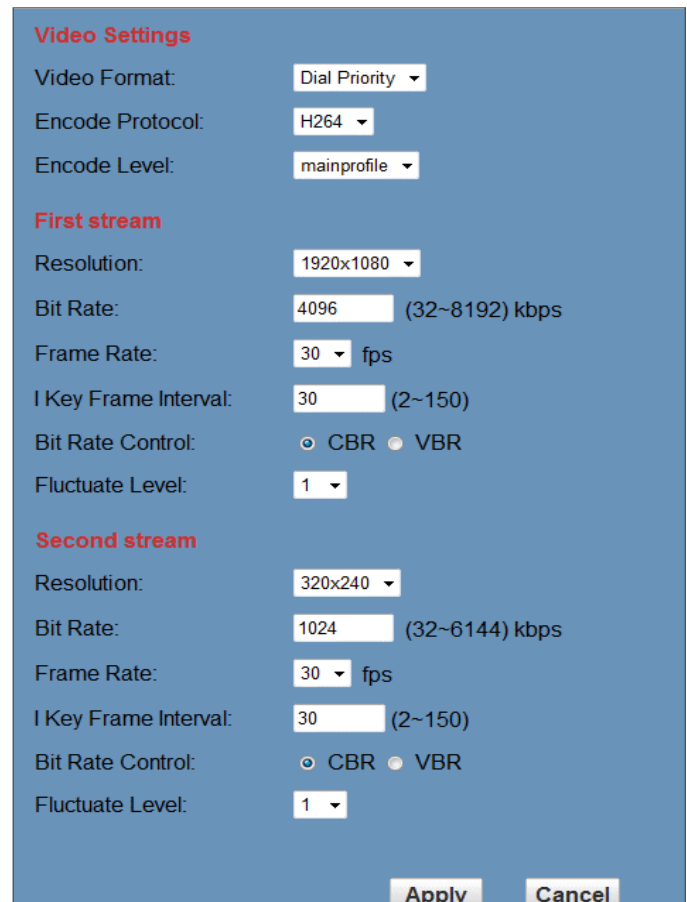

- Fluctuate level
Restrain the fluctuation magnitude of variable rate. Options: 1 - 6

Image Setup

Click “Image.”

- **Brightness**
Image brightness, 0 -14, slider control, on the right shows the corresponding numerical value. The default value is 7.
- **Saturation**
Saturation 0 - 14, slider control, on the right shows the corresponding numerical value. The default value is 4.
- **Contrast**
Contrast 0 - 14, slider control, on the right shows the corresponding numerical value. The default value is 8.
- **Sharpness**
Sharpness 0 - 15, slider control, on the right shows the corresponding numerical value. The default value is 3.
- **Hue**
Hue 0 - 14, slider control, on the right shows the corresponding numerical value. The default value is 6.
- **Flip & Mirror**
Select Flip to turn the image upside down; select Mirror to flip the image horizontally. The default value for both is not selected.
- **Apply, Cancel, and Default Buttons**
After you adjust any parameters, to save the settings click “Apply”; to cancel the parameter adjustments, click “Cancel”. To revert to the default value, click “Default”.



Audio Setup

Click “Audio.”

- **Audio Type**
Option: AAC.
- **Sample rate**
Options: 44.1K and 48K.
- **Bit rate**
Options: 96K, 128K, 256K.
- **Input Type**
Option: line in only
- **Input Vol L and Input Vol R**
The gain of the Line in.
- **Apply and Cancel buttons**
To save changes, click “Apply”, or to discard the changes click “Cancel”.

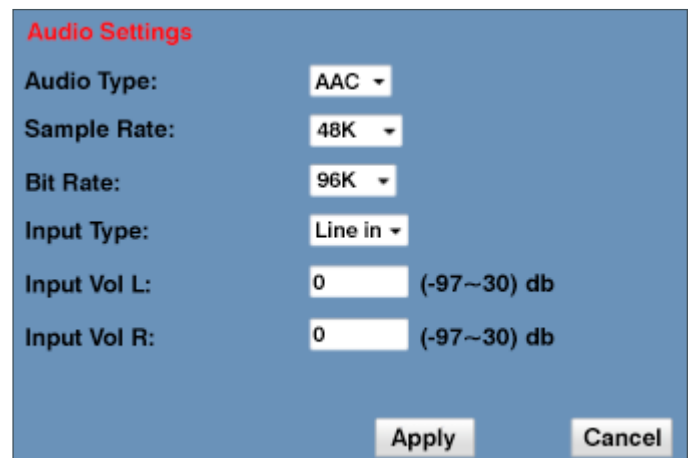

System Setting

Click “System.”

- Work Mode
Work Mode RTSP
- Reboot
Click the “Reboot” button to restart the system.
- User and password
You can modify the password (letters and numbers only)
- Apply / Cancel
Modify the password, then to change the password, click “Apply”, or to cancel the change click “Cancel”.

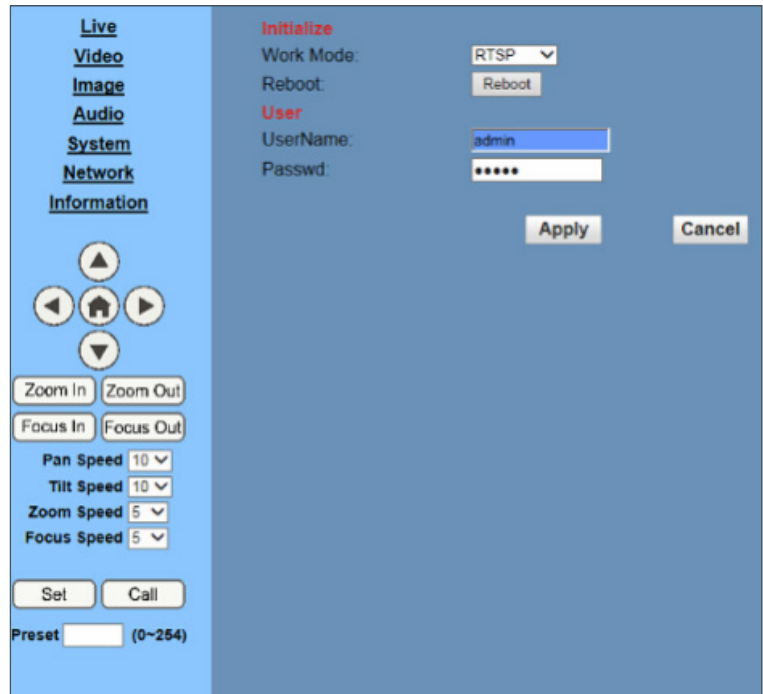

Network Setting

Click “System.”

- LAN Settings
The default IP address is 192.168.100.88. The MAC address can be modified.
- Port Settings
HTTP Port, Default port number: 80
RTSP Port, Supports the RTSP protocol. Default port number: 554.
PTZ Port, Supports PTZ protocol. Default port number: 5678.
- Control Protocol Setting
Camera control communication protocols include Visca address, Pelco-D address, and Pelco-P address.
- RTMP Setting
When configuring the camera stream, can set up two streams, in the two stream selection control code stream of “On”, “Off”, “Video”, “Audio”, etc.
- RTSP Setting
Setting network camera RTSP protocol of “On”, “Off”.
- Multicast Setting
Multicast switch, multicast address (default address 224.1.2.3) and port (default port number: 6688) can be set.
- Apply / Cancel
Modify network parameters then click “Apply” to save the changes, or click “Cancel” to discard the changes.

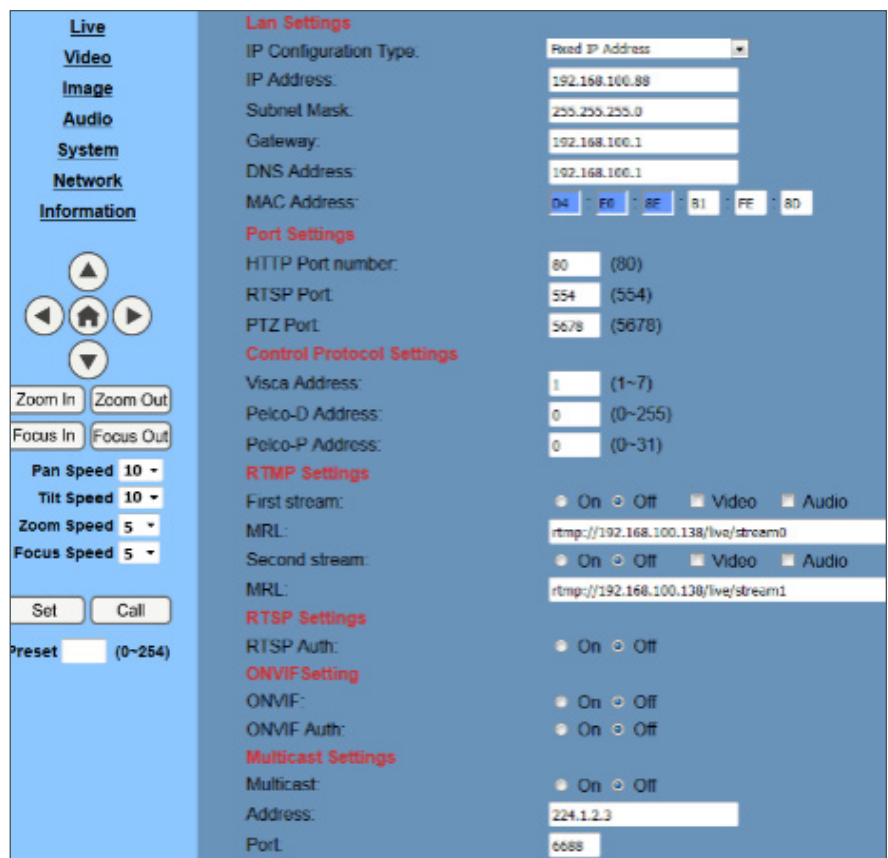

Device Information

Click “Information”, the current device information as shown.

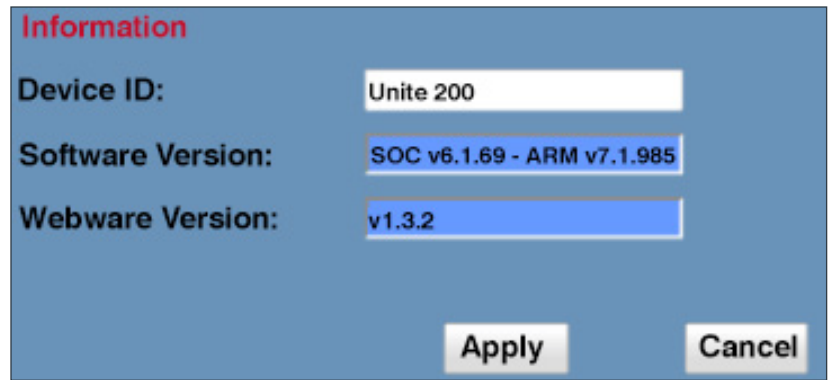

Serial Command Control

In default working mode, the camera can be controlled via RS-232 or RS-485 (half-duplex mode).

The parameters are as follows:

- Baud rate: 2400/4800/9600 bits
- Start bit: 1 bit
- Data bit: 8 bits
- Stop bit: 1bit
- Parity bit: none

The process of initialization is complete when the camera pan-tilt rotates to the maximum position of top right and then returns to the center.



Note: If the position preset 0 has been stored, the position preset 0 is called up after initialization, and users can control the camera with commands in the following command list.

Control Interface Definition

Pin Number	Function
1	DTR
2	DSR
3	TXD
4	GND
5	RXD
6	RS485-
7	IR OUT
8	RS485+

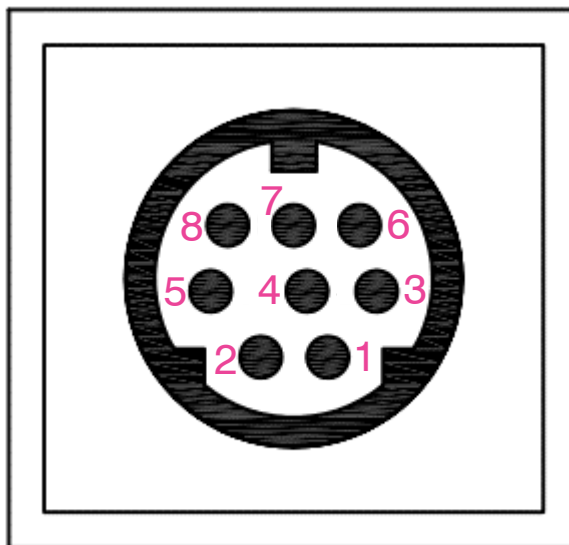

Camera	DB - 9 Serial
1. DTR	1. CD
2. DSR	2. RXD
3. TXD	3. TXD
4. GND	4. DTR
5. RXD	5. GND
6. RS485-	6. DSR
7. IR OUT	7. RTS
8. RS485+	8. CTS
	9. RI

Camera In	Camera Out
1. DTR	1. DTR
2. DSR	2. DSR
3. TXD	3. TXD
4. GND	4. GND
5. RXD	5. RXD
6. RS485-	6. GND
7. IR OUT	7. NC
8. RS485+	8. NC

Network Configuration

With VISCA

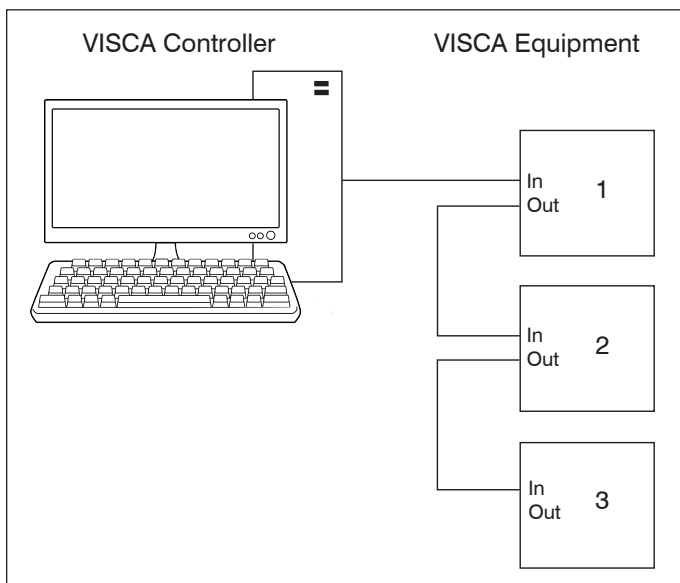

With Pelco

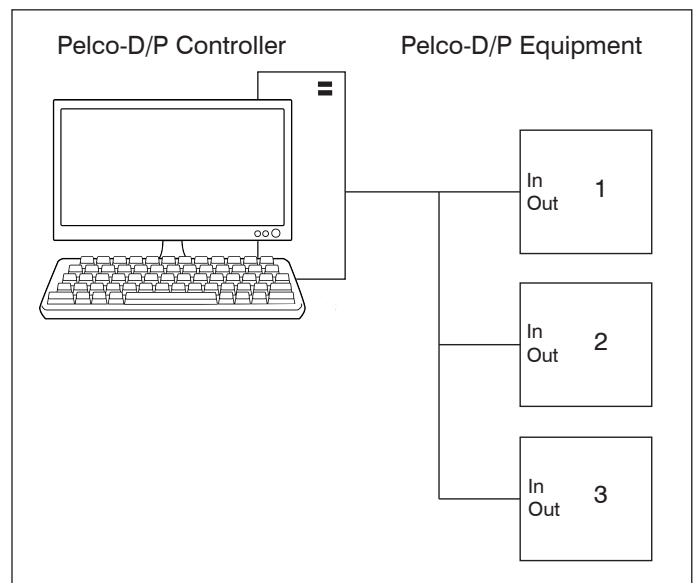

Command List

The camera uses the VISCA/Pelco-D/Pelco-P serial standard.

Camera-Issued Messages

Note: In the following tables, z = Camera Address + 8

ACK/ Completion Message			
Command	Function	Command Packet	Comments
ACK/ Completion Messages	ACK	z0 4y FF (y: Socket No.)	Returned when the command is accepted.
	Completion	z0 5y FF (y: Socket No.)	Returned when the command has been executed.

Error Messages			
Command	Function	Command Packet	Comments
Error Messages	Syntax Error	z0 60 02 FF	Returned when the command format is different or when a command with illegal command parameters is accepted.
	Command Buffer Full	z0 60 03 FF	Indicates that two sockets are already being used (executing two commands) and the command could not be accepted when received.
	Command Canceled	z0 6y 04 FF (y: Socket No.)	Returned when a command which is being executed in a socket specified by the cancel command is canceled. The completion message for the command is not returned.
	No Socket	z0 6y 05 FF (y: Socket No.)	Returned when no command is executed in a socket specified by the cancel command, or when an invalid socket number is specified.
	Command Not Executable	z0 6y 41 FF (y: Execution command Socket No. Inquiry command: 0)	Returned when a command can't be executed due to current conditions. For example, when commands controlling the focus manually are received during auto focus.

Camera Control Commands

Command	Function	Command Packet	Comments
AddressSet	Broadcast	88 30 01 FF	Address setting
CAM_Zoom	Stop	8x 01 04 07 00 FF	
	Tele(Standard)	8x 01 04 07 02 FF	
	Wide(Standard)	8x 01 04 07 03 FF	
	Tele(Variable)	8x 01 04 07 2p FF	p = 0(low) - 7(high)
	Wide(Variable)	8x 01 04 07 3p FF	
	Direct	8x 01 04 47 0p 0q 0r 0s FF	pqrs: Zoom Position
CAM_Focus	Stop	8x 01 04 08 00 FF	
	Far(Standard)	8x 01 04 08 02 FF	
	Near(Standard)	8x 01 04 08 03 FF	
	Far(Variable)	8x 01 04 08 2p FF	p = 0(low) - 7(high)
	Near(Variable)	8x 01 04 08 3p FF	
	Direct	8x 01 04 48 0p 0q 0r 0s FF	pqrs: Focus Position
	Auto Focus	8x 01 04 38 02 FF	AF On/Off
	Manual Focus	8x 01 04 38 03 FF	
	Auto/Manual	8x 01 04 38 10 FF	
CAM_WB	Auto	8x 01 04 35 00 FF	Normal Auto
	Indoor mode	8x 01 04 35 01 FF	Indoor mode
	Outdoor mode	8x 01 04 35 02 FF	Outdoor mode
	OnePush mode	8x 01 04 35 03 FF	One Push WB mode
	Manual	8x 01 04 35 05 FF	Manual Control mode
	OnePush trigger	8x 01 04 10 05 FF	One Push WB Trigger
CAM_RGain	Reset	8x 01 04 03 00 FF	Manual Control of R Gain
	Up	8x 01 04 03 02 FF	
	Down	8x 01 04 03 03 FF	
	Direct	8x 01 04 43 00 00 0p 0q FF	pq: R Gain
CAM_Bgain	Reset	8x 01 04 04 00 FF	Manual Control of B Gain
	Up	8x 01 04 04 02 FF	
	Down	8x 01 04 04 03 FF	
	Direct	8x 01 04 44 00 00 0p 0q FF	pq: B Gain
CAM_AE	Full Auto	8x 01 04 39 00 FF	Automatic Exposure mode
	Manual	8x 01 04 39 03 FF	Manual Control mode
	Shutter priority	8x 01 04 39 0A FF	Shutter Priority Automatic Exposure mode
	Iris priority	8x 01 04 39 0B FF	Iris Priority Automatic Exposure mode
	Bright	8x 01 04 39 0D FF	Bright mode (Manual control)

Command	Function	Command Packet	Comments
CAM_Iris	Reset	8x 01 04 0B 00 FF	Iris Setting
	Up	8x 01 04 0B 02 FF	
	Down	8x 01 04 0B 03 FF	
	Direct	8x 01 04 4B 00 00 0p 0q FF	pq: Iris Position
CAM_Gain	Reset	8x 01 04 0C 00 FF	Gain Setting
	Up	8x 01 04 0C 02 FF	
	Down	8x 01 04 0C 03 FF	
	Direct	8x 01 04 0C 00 00 0p 0q FF	pq: Gain Position
	Gain Limit	8x 01 04 2C 0p FF	p: Gain Position
CAM_Bright	Reset	8x 01 04 0D 00 FF	Bright Setting
	Up	8x 01 04 0D 02 FF	
	Down	8x 01 04 0D 03 FF	
	Direct	8x 01 04 0D 00 00 0p 0q FF	pq: Bright Position
CAM_ExpComp	On	8x 01 04 3E 02 FF	Exposure Compensation On/Off
	Off	8x 01 04 3E 03 FF	
	Reset	8x 01 04 0E 00 FF	Exposure Compensation Amount Setting
	Up	8x 01 04 0E 02 FF	
	Down	8x 01 04 0E 03 FF	
	Direct	8x 01 04 4E 00 00 0p 0q FF	
CAM_BackLight	On	8x 01 04 33 02 FF	Back Light Compensation On/Off
	Off	8x 01 04 33 03 FF	
CAM_NR(2D)Mode	Auto	8x 01 04 50 02 FF	ND2D Auto/Manual
	Manual	8x 01 04 50 03 FF	
CAM_NR(2D)Level	-	8x 01 04 53 0p FF	p: NR Setting (0: Off, level 1 to 5)
CAM_NR(3D)Level	-	8x 01 04 54 0p FF	p: NR Setting (0: Off, level 1 to 8)
CAM_Flicker	-	8x 01 04 23 0p FF	p: Flicker Settings (0: Off, 1: 50Hz, 2: 60Hz)
CAM_DHotPixel	-	8x 01 04 56 0p FF	p: Dynamic Hot Pixel Setting (0: Off, level 1 to 6)
CAM_ApertureMode (sharpness)	Auto	8x 01 04 05 02 FF	Sharpness Auto
	Manual	8x 01 04 05 02 FF	Sharpness Manual
CAM_Aperture (sharpness)	Reset	8x 01 04 02 00 FF	Aperture Control
	Up	8x 01 04 02 02 FF	
	Down	8x 01 04 02 03 FF	
	Direct	8x 01 04 42 00 00 0p 0q FF	pq: Aperture Gain
CAM_PictureEffect	Off	8x 01 04 63 00 FF	Picture Effect Setting
	B&W	8x 01 04 63 04 FF	
CAM_Memory	Reset	8x 01 04 3F 00 pp FF	pp: Memory Number(=0 to 127)
	Set	8x 01 04 3F 01 pp FF	
	Recall	8x 01 04 3F 02 pp FF	

Command	Function	Command Packet	Comments
CAM_LR_Reverse	On	8x 01 04 61 02 FF	Image Flip Horizontal On/Off
	Off	8x 01 04 61 03 FF	
CAM_PictureFlip	On	8x 01 04 66 02 FF	Image Flip Vertical On/Off
	Off	8x 01 04 66 03 FF	
CAM_ColorGain	Diret	8x 01 04 49 00 00 00 0p FF	p: Color Gain setting 0h (60%) to Eh (200%)
SYS_Menu	Off	8x 01 06 06 03 FF	Turns on/off the menu screen
	On	8x 01 06 06 02 FF	
Pan_tiltDrive	Up	8x 01 06 01 VV WW 03 01 FF	VV: Pan speed 0x01 (low speed) to 0x18 (high speed) WW: Tilt speed 0x01 (low speed) to 0x14 (high speed) YYYY: Pan Position ZZZZ: Tilt Position
	Down	8x 01 06 01 VV WW 03 02 FF	
	Left	8x 01 06 01 VV WW 01 03 FF	
	Right	8x 01 06 01 VV WW 02 03 FF	
	Upleft	8x 01 06 01 VV WW 01 01 FF	
	Upright	8x 01 06 01 VV WW 02 01 FF	
	DownLeft	8x 01 06 01 VV WW 01 02 FF	
	DownRight	8x 01 06 01 VV WW 02 02 FF	
	Stop	8x 01 06 01 VV WW 03 03 FF	
	AbsolutePosition	8x 01 06 02 VV WW 0Y 0Y 0Y 0Y 0Z 0Z 0Z 0Z FF	
	RelativePosition	8x 01 06 03 VV WW 0Y 0Y 0Y 0Y 0Z 0Z 0Z 0Z FF	
	Home	8x 01 06 04 FF	
	Reset	8x 01 06 05 FF	
Pan_tiltLimitSet	LimitSet	8x 01 06 07 00 0W 0Y 0Y 0Y 0Y 0Z 0Z 0Z 0Z FF	W: 1 UpRight 0: DownLeft YYYY: Pan Limit Position ZZZZ: Tilt Position
	LimitClear	8x 01 06 07 01 0W 07 0F 0F 0F 07 0F 0F 0F FF	
CAM_AFSensitivity	High	8x 01 04 58 01 FF	AF Sensitivity High/Normal/Low
	Normal	8x 01 04 58 02 FF	
	Low	8x 01 04 58 03 FF	
CAM_SettingReset	Reset	8x 01 04 A0 10 FF	Reset Factory Setting
CAM_Brightness	Direct	8x 01 04 A1 00 00 0p 0q FF	pq: Brightness Position
CAM_Contrast	Direct	8x 01 04 A2 00 00 0p 0q FF	pq: Contrast Position
CAM_Flip	Off	8x 01 04 A4 00 FF	Single Command For Video Flip
	Flip-H	8x 01 04 A4 01 FF	
	Flip-V	8x 01 04 A4 02 FF	
	Flip-HV	8x 01 04 A4 03 FF	
CAM_SettingSave	Save	8x 01 04 A5 10 FF	Save Current Setting
CAM_Iridix	Direct	8x 01 04 A7 00 00 0p 0q FF	pq: Iridix Position
CAM_AWBSensitivity	High	8x 01 04 A9 00 FF	High
	Normal	8x 01 04 A9 01 FF	Normal
	Low	8x 01 04 A9 02 FF	Low

Command	Function	Command Packet	Comments
CAM_AFZone	Top	8x 01 04 AA 00 FF	AF Zone weight select
	Center	8x 01 04 AA 01 FF	
	Bottom	8x 01 04 AA 02 FF	
CAM_ColorHue	Direct	8x 01 04 4F 00 00 00 0p FF	p: Color Hue setting 0h (- 14 dgees) to Eh (+14 degrees)

Demand Command

Command	Command Packed	Return Values	Comments
CAM_ZoomPosInq	8x 09 04 47 FF	y0 50 0p 0q 0r 0s FF	pqrs: Zoom Position
CAM_FocusAFModelInq	8x 09 04 38 FF	y0 50 02 FF	Auto Focus
		y0 50 03 FF	Manual Focus
CAM_FocusPosInq	8x 09 04 48 FF	y0 50 0p 0q 0r 0s FF	pqrs: Focus Position
CAM_WBModelInq	8x 09 04 35 FF	y0 50 00 FF	Auto
		y0 50 01 FF	Indoor mode
		y0 50 02 FF	Outdoor mode
		y0 50 03 FF	OnePush mode
		y0 50 05 FF	Manual
CAM_RGainInq	8x 09 04 43 FF	y0 50 00 00 0p 0q FF	pq: R Gain
CAM_BGainInq	8x 09 04 44 FF	y0 50 00 00 0p 0q FF	pq: B Gain
CAM_AEModelInq	8x 09 04 39 FF	y0 50 00 FF	Full Auto
		y0 50 03 FF	Manual
		y0 50 0A FF	Shutter priority
		y0 50 0B FF	Iris priority
		y0 50 0D FF	Bright
CAM_ShutterPosInq	8x 09 04 4A FF	y0 50 00 00 0p 0q FF	pq: Shutter Position
CAM_IrisPosInq	8x 09 04 4B FF	y0 50 00 00 0p 0q FF	pq: Iris Position
CAM_BrightPosInq	8x 09 04 4D FF	y0 50 00 00 0p 0q FF	pq: Bright Position
CAM_ExpCompModelInq	8x 09 04 3E FF	y0 50 02 FF	On
		y0 50 03 FF	Off
CAM_ExpCompPosInq	8x 09 04 4E FF	y0 50 00 00 0p 0q FF	pq: ExpComp Position
CAM_BacklightModelInq	8x 09 04 33 FF	y0 50 02 FF	On
		y0 50 03 FF	Off
CAM_Nosise2DModelInq	8x 09 04 50 FF	y0 50 02 FF	Auto Noise 2D
		y0 50 03 FF	Manual Noise 3D
CAM_Nosise2DLevel	8x 09 04 53 FF	y0 50 0p FF	Noise Reduction (2D) p: 0 to 5
CAM_Noise3DLevel	8x 09 04 54 FF	y0 50 0p FF	Noise Reduction (3D) p: 0 to 8
CAM_FlickerModelInq	8x 09 04 55 FF	y0 50 0p FF	p: Flicker Settings(0: OFF, 1: 50Hz, 2: 60Hz)
CAM_ApertureModelInq (Sharpness)	8x 09 04 05 FF	y0 50 02 FF	Auto Sharpness
		y0 50 03 FF	Manual Sharpness

Command	Command Packed	Return Values	Comments
CAM_ApertureInq (Sharpness)	8x 09 04 42 FF	y0 50 00 00 0p 0q FF	pq: Aperture Gain
CAM_PictureEffectModelInq	8x 09 04 63 FF	y0 50 02 FF	Off
		y0 50 04 FF	B&W
CAM_MemoryInq	8x 09 04 3F FF	y0 50 0p FF	p: Memory number last operated.
SYS_MenuModelInq	8x 09 06 06 FF	y0 50 02 FF	On
		y0 50 03 FF	Off
CAM_LR_ReverseInq	8x 09 04 61 FF	y0 50 02 FF	On
		y0 50 03 FF	Off
CAM_PictureFlipInq	8x 09 04 66 FF	y0 50 02 FF	On
		y0 50 03 FF	Off
CAM_ColorGainInq	8x 09 04 49 FF	y0 50 00 00 00 0p FF	p: Color Gain setting 0h (60%) to Eh (200%)
VideoSystemInq	8x 09 06 23 FF	y0 50 00 FF	1920x1080i60
		y0 50 01 FF	1920x1080p30
		y0 50 02 FF	1280x720p60
		y0 50 04 FF	NTSC
		y0 50 05 FF	NTSC
		y0 50 06 FF	NTSC
		y0 50 07 FF	1920x1080p60
		y0 50 08 FF	1920x1080i50
		y0 50 09 FF	1920x1080p25
		y0 50 0A FF	1280x720p50
		y0 50 0C FF	PAL
		y0 50 0E FF	PAL
Pan-tiltMaxSpeedInq	8x 09 06 11 FF	y0 50 ww zz FF	ww: Pan Max Speed zz: Tilt Max Speed
Pan-tiltPosInq	8x 09 06 12 FF	y0 50 0w 0w 0w 0w 0z 0z 0z 0z FF	www: Pan Position zzzz: Tilt Position
CAM_GainLimitInq	8x 09 04 2C FF	y0 50 0q FF	p: Gain Limit
CAM_DHotPixelInq	8x 09 04 56 FF	y0 50 0q FF	p: Dynamic Hot Pixel Setting (0: Off, level 1 to 6)
CAM_AFSensitivityInq	8x 09 04 58 FF	y0 50 01 FF	High
		y0 50 02 FF	Normal
		y0 50 03 FF	Low
CAM_BrightnessInq	8x 09 04 A1 FF	y0 50 00 00 0p 0q FF	pq: Brightness Position
CAM_ContrastInq	8x 09 04 A2 FF	y0 50 00 00 0p 0q FF	pq: Contrast Position
CAM_FlipInq	8x 09 04 A4 FF	y0 50 00 FF	Off
		y0 50 01 FF	Flip-H
		y0 50 02 FF	Flip-V
		y0 50 03 FF	Flip-HV

Command	Command Packed	Return Values	Comments
CAM_IridixInq	8x 09 04 A7 FF	y0 50 00 00 0p 0q FF	pq: Iridix Position
CAM_AFZone	8x 09 04 AA FF	y0 50 00 FF	Top
		y0 50 01 FF	Center
		y0 50 02 FF	Bottom
CAM_ColorHueInq	8x 09 04 4F FF	y0 50 00 00 00 0p FF	p: Color Hue setting 0 h (– 14 degrees) to E h (+14 degrees)
CAM_AWBSensitivityInq	8x 09 04 A9 FF	y0 50 00 FF	High
		y0 50 01 FF	Normal
		y0 50 02 FF	Low

Maintenance and Troubleshooting

Camera Maintenance

- If you choose not to use your camera for a long time, turn off the power switch and disconnect AC power cord of AC adapter to the outlet.
- Use soft cloth to clean the camera cover.
- Use the soft dry cloth to clean the lens. If the camera is very dirty, clean it with diluted neutral detergent. Do not use any type of solvents, which may damage the surface.

Unqualified Application

- Do not shoot extremely bright objects for a long period of time, such as sunlight, strong light sources, etc.
- Do not operate in unstable lighting conditions, as image may flicker.

Troubleshooting

Trouble	Solution
No Image	<ul style="list-style-type: none"> • Check whether the power cord is connected, voltage is OK, POWER lamp is lit. • Check whether the camera can self-test after start up. • Check the video cable to make sure it is connected correctly.
Abnormal display of image	<ul style="list-style-type: none"> • Check the video cable to make sure it is connected correctly.
Image dithering even at widest zoom position	<ul style="list-style-type: none"> • Check whether the camera is fixed correctly. • Make sure there is nothing nearby causing vibrations.
IE browser does not show video image	<ul style="list-style-type: none"> • When the camera is accessed the first time by Internet Explorer (or another web browser), you must install the plug-in. • The first time you use the camera by internet (only for new user), you must install the player software (VLC). Please go to VLC website http://www.videolan.org/vlc and Install VLC (player software). • After installation, log in again. You should see the video stream on the home page of the Web interface.

Trouble	Solution
Unable to access IP Camera by browser	<ul style="list-style-type: none"> • To rule out cable failure or network failure caused by a virus, make sure your computer is connected to the network, Make sure you can ping the computer from another computer and that computer can ping other computers on the local network or the gateway. • Disconnect the camera from the network, ensure that the camera and PC are connected (either directly, with a crossover cable, or with a router or switch), and then follow the directions earlier in this guide to reset the IP address. • Check the server's IP address and subnet mask and gateway address. • Check for MAC address conflicts. • Make sure the HTTP port is not occupied by other devices, or that routing rules are not sending the traffic to a different address or port.
IP address modified incorrectly or forgot Web interface password	<ul style="list-style-type: none"> • You can recover access to the camera with use of the IR remote control. Press "[*] + [#] + [Manual]" to restore the default values (default IP: 192.168.100.88, default username: admin, default password: admin).
The IR remote control cannot control the camera	<ul style="list-style-type: none"> • Change the remote control battery. • Check the camera working mode. • Check that the IR address of the Remote Commander is set correctly.
Serial communication cannot control the camera	<ul style="list-style-type: none"> • Check the camera working mode. • Check that the control cable is connected correctly.